

Modular, compact and flexible solution for side casepacking in wrap cases, designed for medium/high capacities.

An accessible and user-friendly equipment, designed to handle flexible, rigid or semi-rigid packages. It is adaptable to the most convenient grouping system according to the characteristics of the product

The NWG-20 allows productions up to 18 cases/min. Its technology is built to operate with soft movements, treating the product in a delicate way.

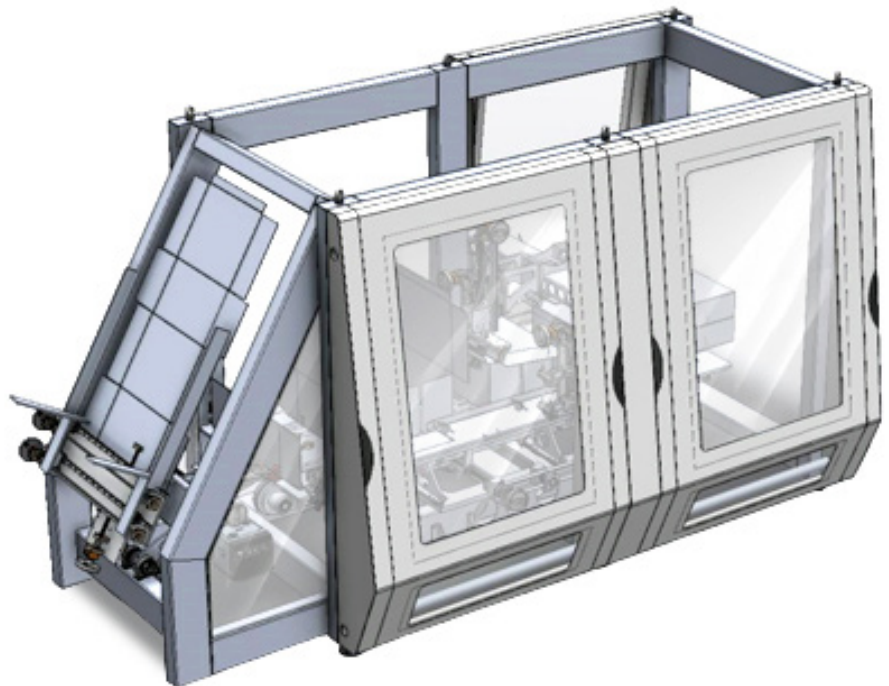

Features

- ✘ Production up to 18 cartons/minute.
- ✘ 3 stations: forming, filling and closing
- ✘ Servo-controlled system.
- ✘ Modular structure composed by grouping unit and case packing unit, with closing by Hot Melt
- ✘ Optional blanks magazine for high capacity and autonomy for up to 500 carton sheets.
- ✘ Automatic format changeover (optional)

Benefits

- ✘ Ergonomic and compact design
- ✘ Easy to access for maintenance
- ✘ Versatile machine to adapt to different formats
- ✘ HMI (Human-Machine Interface) screen with complete and intuitive software

Box types

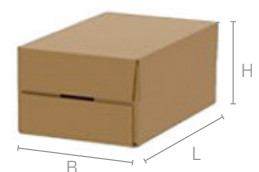
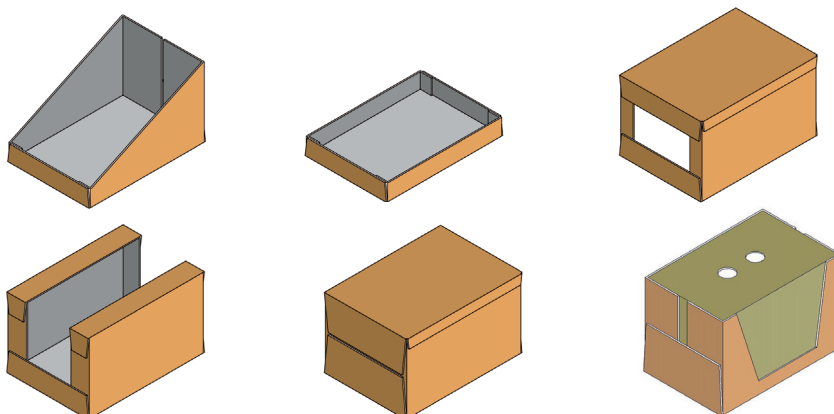

	L	B	H
Max	500	350	300
Min	170	80	120